

SQX Series

Square Inline Fans

OPERATION & MAINTENANCE MANUAL



PENNBARRY™

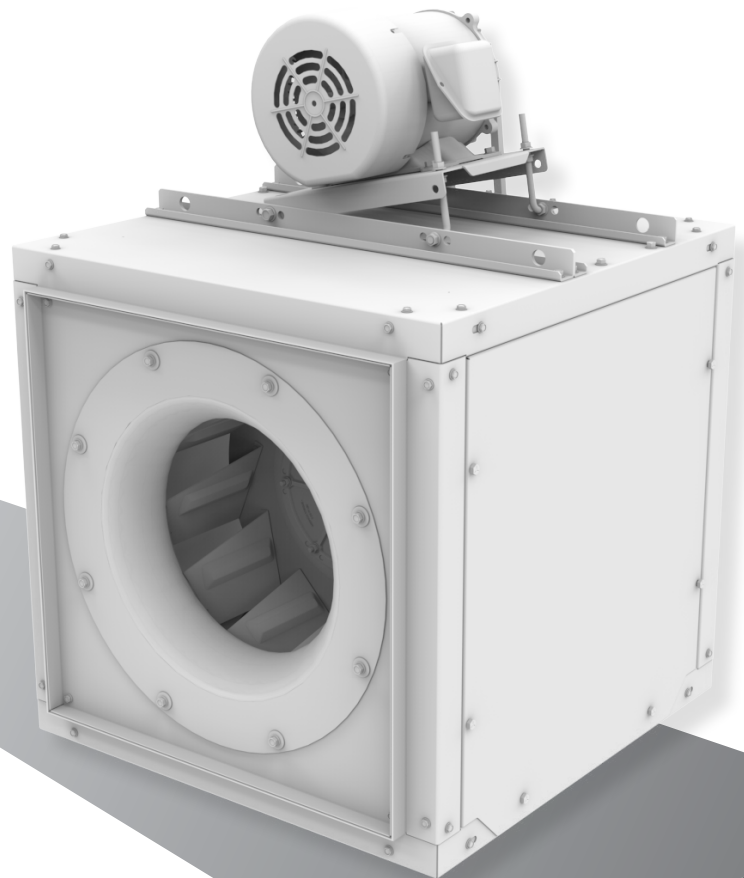

IMPORTANT! Read before proceeding!

Please read and save these instructions. Read carefully before attempting to assemble, install, operate or maintain the product described. Protect yourself and others by observing all safety information. Failure to comply with instructions could result in personal injury and/or property damage! Retain instructions for future reference.

TABLE OF CONTENTS

| | |
|--|-------|
| INTRODUCTION | 3 |
| INSTALLATION | 4 |
| START-UP AND OPERATION | 5 |
| PRE-START-UP CHECKS | 6 |
| START-UP AND OPERATION | 7-8 |
| MAINTENANCE | 9-10 |
| PARTS REPLACEMENTS | 11-12 |
| TROUBLESHOOTING CHECKLIST | 13 |
| WHEEL ALIGNMENT PROCEDURES | 14 |
| WIRING SCHEMATICS - ECM | 15-16 |
| WIRING - PM/AC MOTOR WITH SPEED CONTROLLER/VFD | 17-19 |

INTRODUCTION

Receiving and handling

PennBarry fans are carefully inspected before leaving the factory. When the unit is received, inspect the carton for any signs of tampering. Inspect the unit for any damage that may have occurred during transit and check for loose, missing or damaged parts. Mishandled units can void the warranty provisions. If units are damaged in transit, it is the responsibility of the receiver to make all claims against the carrier. PennBarry is not responsible for damages incurred during shipment.

Avoid severe jarring and/or dropping. Handle units with care to prevent damage to components or finishes. If the unit is scratched due to mishandling, the protective coating may be damaged. Incorrect lifting may damage the fan and void the warranty.

Storage

Long-term storage requires special attention. Store units on a level, solid surface, preferably indoors. If outside storage is necessary, protect the units against moisture and dirt by encasing the cartons in plastic or in some similar weatherproof material. Periodically inspect units and rotate wheels to spread bearing lubricant. Failure to rotate wheels results in reduced bearing life and may void the manufacturer's warranty. If the unit will be stored for an extended time, remove belts. Belts which remain under tension in a stationary position for extended periods are likely to have a reduced operating life.

Unpacking

Place the carton in an upright position and remove the staples or use a sharp (knife edge) tool to carefully cut or scribe the sealing tape on both sides at the top of the carton. Open carton flaps. Remove any cardboard and wooden filler pieces, as well as loose components or accessories shipped with the unit.

Carefully remove the unit from the carton. Inspect the unit for any damage that may have occurred during transit and check for loose, missing or damaged parts.



The SQX square inline fan is suitable only for indoors applications. This fan is NOT suitable for outdoors installations. Installing this product in different ways that recommended by the manufacturer voids the warranty.



INSTALLATION

Fans must be directly supported by building structure. Follow building's blue prints carefully when installing.

INSTALLING THE DAMPERS

When required, dampers must be positioned and fastened to the duct or fan housing.

Figure 1: Duct Assembly

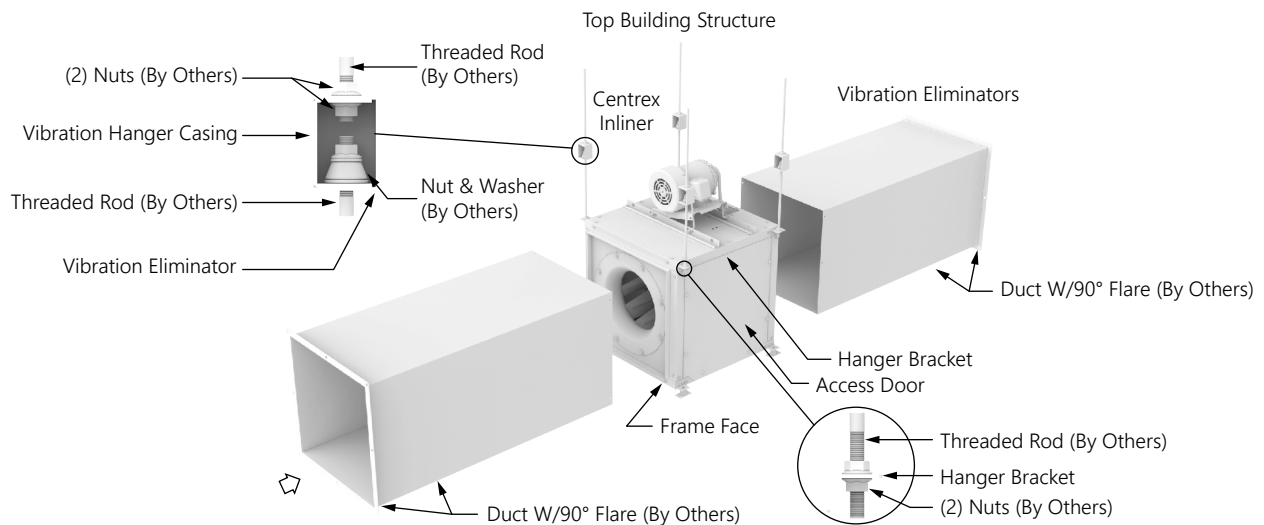

POSITIONING AND RUNNING POWER LINES

Power is normally brought from within the building through proper conduit lines to the unit. It is then fed to the (service switch, if furnished, and) motor. A grounding wire and a 12-gauge line wire are provided between the motor and a junction box mounted on the exterior of the fan housing. Motor fuses to be time delayed type.



When unit positioning necessitates motor mounting to the side of the unit, Pennbarry recommends motors up to 2 HP. Selection of a higher HP motor may void warranty.

ANCHORING AND SECURING THE VENTILATOR

Inliners are designed for all angle mounting. Method of installation is dependent upon job conditions and may, under specific circumstances, require support legs, angle supports or casing brackets. Vibration eliminators, where required, should be installed jointly with the units. Flexible duct connectors are common accessories and, if used, should overlap the duct at least 2". Test wheel for freedom of movement before installing unit. If wheel does not rotate freely, then loosen venturi screws, move venturi until wheel rotates freely, and tighten screws.

It is particularly important to remember that the venturi end is the inlet side of the Inliner. Position the unit so that it aligns with the airflow direction desired; the inlet is marked "Inlet Side".

When the Inliner has been placed into its proper position, connect it to the duct system. Ducts on the inlet and discharge sides should be the same height and width as the inside dimensions of the square housing frame. Flare out the ductwork 90° to easily screw to faces of unit. A length 2.5 times the housing square should be installed before elbows or transitions are used.

Appropriately sized fasteners should be used and drawn secure and tight. Correct fan wheel rotation should be in the direction of the arrow affixed to the unit. Normally, the wheel should rotate clockwise when looking into the inlet side of the Inliner.



Some local codes prohibit the connection of inline, aluminum fans in kitchen hood exhaust systems. According to present NFPA96 interpretation, ANY fan used in such duct work must be made of steel, with liquidtight welds at all seams and connections. If local codes are in accordance with NFPA96, do not use ANY FAN that is not completely welded closed for such duty. Refer to PennBarry's Fumex and Dynamo products for roof and wall mounted exhausters approved for use on kitchen hood exhaust systems.

START-UP AND OPERATION

Carefully inspect the unit before start-up. All motor fasteners should be securely tightened. Centrifugal wheel should be rotated by hand to ensure free movement. See next page for wheel alignment procedure. (NOTE: Before placing hand on centrifugal wheel or belts, lock out power source.) Check all set-screws and keys. Tighten when necessary.

Check the condition of belts and the amount of tension prior to start-up. DO NOT over tighten, as bearing damage will occur. Recommended belt tension should permit deflection of 1/64" per inch of belt span measured halfway between the pulley centerline. Exercise extreme care when adjusting belts as not to misalign the pulleys. Any misalignment will cause a sharp reduction in belt life and produce squeaky, annoying noises. On units equipped with two or three groove pulleys, adjustments must be made so that there is equal tension on all belts.

Figure 2: Pulley Alignment

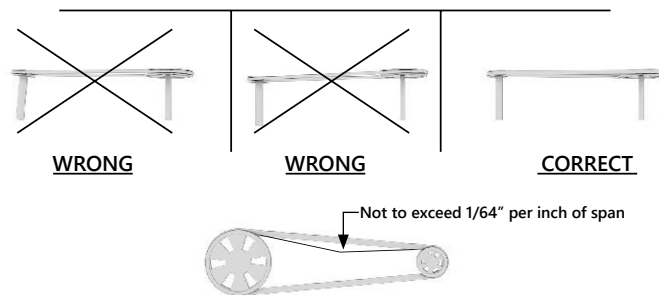

Whenever belts are removed or installed, never force belts over pulleys without loosening motor first to relieve belt tension.

Make sure inlets and approaches to the unit are free from obstruction.

When power lines are brought up to the unit, provide a generous amount of slack to allow for motor deflections and to permit movement of motor for belt tension adjustments. Ground motor adequately and securely. Protect power lines from sharp objects. Do not kink power line or permit it to contact hot surfaces, chemicals, grease or oil. Use only UL recognized electrical parts, rated for proper voltage, load and environment.

Before putting fan into operation, complete the following checklist:

- a. Turn off power source.
- b. Make sure installation is in accordance with manufacturer's instructions.
- c. Check and tighten all fasteners.
- d. Spin centrifugal wheel to see if rotation is free.
- e. Check all set-screws and keys; tighten if necessary.
- f. Torqued set screws have a colored Torque Seal mark indicating the correct torque has been applied.
- g. Check belt or direct drive coupling for alignment (use recommended belt tension gauges).
- h. Check belt for proper sheave selection.
- i. Make sure there is no foreign or loose material in ductwork leading to and from fan or in the fan itself.
- j. Properly secure all safety guards.
- k. Secure all access doors to fan and ductwork.
- l. Check line voltage with motor nameplate.
- m. Check wiring.

PRE-START-UP CHECKS

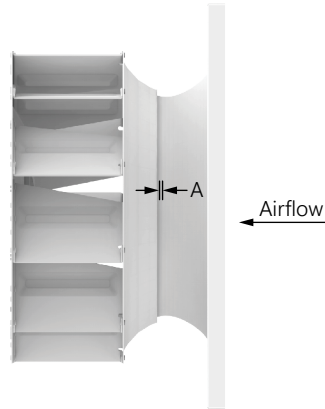

Ensure that all mounting hardware and fasteners are properly installed and tightened to recommended torque specifications.

Ensure that the wheel is aligned and has the correct spacing in relation to the inlet venturi; it should be centered in the inlet venturi as well. If adjustment is needed, loosen the inlet venturi bolts and shift the inlet venturi until the radial gap is the same at every point across the circumference of the inlet venturi.

If adjustment of the overlap between the wheel and inlet venturi is needed, loosen the taper lock bushing, slide the wheel forwards or backwards until the correct overlap is achieved, and then tighten the set screws back down.

There is a rotation sticker on the unit that specifies the direction the wheel should turn. Ensure that the wheel is rotating in the proper direction before powering on the unit. In 3 phase units, simply switch two incoming leads to reverse rotation.

Notes: Any increase in fan speed represents a substantial increase in horsepower required from the motor. Always check motor load amperage and compare to nameplate rating when changing fan speed.

| Gap/Overlap dimension | |
|-----------------------|--|
| Size | Wheel Venturi Overlap (Dimension A – inches) |
| 100 (60,70 and 80) | 0.22 |
| 122 | 0.27 |
| 135 | 0.30 |
| 150 | 0.33 |
| 165 | 0.36 |
| 182 | 0.40 |
| 200 | 0.44 |
| 222 | 0.49 |
| 245 | 0.54 |
| 270 | 0.59 |
| 300 | 0.66 |
| 330 | 0.72 |
| 365 | 0.80 |
| 402 | 0.88 |

START-UP AND OPERATION



On single phase motors, the terminal block must be set up in accordance with the nameplate instructions and/or wiring diagram. This set up must match the line voltage. If the motor is multi-speed or multi-voltage, the winding leads must be grouped and connected as shown on the motor wiring diagram. The line voltage must correspond with proper grouping of motor leads. The wiring diagram must be followed explicitly, or serious motor or starter damage will occur.

The ventilator has been checked at the factory prior to shipment for mechanical noises. If mechanical noises should develop:

- a. Check rotating components for adequate clearance.
- b. Check proper belt tension and pulley alignment.
- c. Check installation and anchoring.
- d. Check fan bearings.

Switch on electrical supply and allow fan to reach full speed. Check carefully for:

1. Correct rotation of the centrifugal wheel.



Incorrect rotation overloads motor severely and results in serious motor damage. To change rotation of three phase units, interchange any 2 of the 3 line leads. On single phase units, change the terminal block set-up following the wiring diagram on the motor.

2. Check motor and bearing temperatures for excessive heat.



Use care when touching the exterior of an operating motor. Modern motors normally run hot. They are designed to operate at higher temperatures. This is a normal condition, but they may be hot enough to be painful or injurious to the touch.

If any problem is indicated, **TURN OFF POWER TO UNIT IMMEDIATELY**. Lock out the electrical supply, check carefully for the cause of the trouble, and correct as needed. Even if the fan appears to be operating satisfactorily, shut down after a brief period and check all fasteners, set-screws and keys for tightness.

During the first eight (8) hours of operation, check the fan periodically for excessive vibration or noise. At this time, also check motor input current and motor bearing temperatures to ensure that they do not exceed manufacturer's recommendations. After eight hours of satisfactory operation, shut down the fan and lock out the electrical power to check the following items and adjust if necessary:

- a. All set-screws, keys and fasteners.
- b. Drive coupling alignment.
- c. Belt alignment.
- d. Belt tension.

START-UP AND OPERATION

GPLUS EC MOTOR SPEED ADJUSTMENT

To adjust the motor speed on a fan with a Gplus EC motor, please remove the side unit access panel and the access panel for the potentiometer as shown on figure 7a"

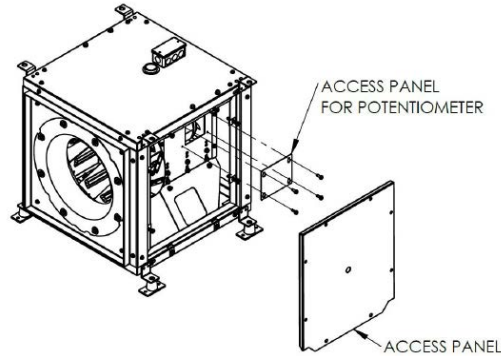

NOTE :
SIZE 100-165 : "ACCESS PANEL FOR POTENTIOMETER ADJUSTMENT"



WARNING

Unit should be fully disconnected from the main power source and any rotational parts from the fan fully stopped BEFORE removing an access panel from the unit. Care should be taken to follow all local electrical, safety and building codes. Provisions of the National Electric Code (NEC), as well as the Occupational Safety and Health Act (OSHA) should be followed.

HANGER BRACKET/MOUNTING FEET INSTALLATION

The direct drive fan shipped with preinstalled lifting lug and hanger bracket/mounting feet shipped loose with the fan.

1. Remove lifting lug from direct drive fan
2. Install hanger bracket or Mounting feet as per figure shown
3. Remember to cross check correct type of bracket and hardware

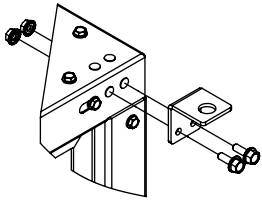

Hanger Bracket Installation
(Horizontal Mounting)

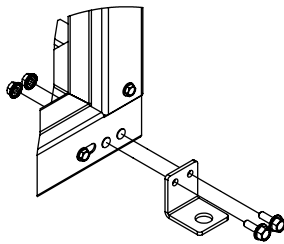

Mounting Feet Installation
(Horizontal Mounting)

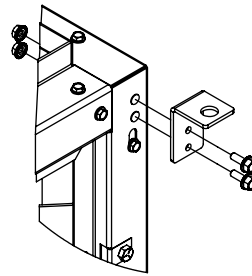

Hanger Bracket Installation
(Vertical Mounting)

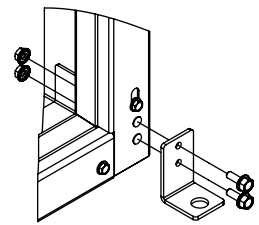

Mounting Feet Installation
(Vertical Mounting)

MAINTENANCE

Do not attempt maintenance on a fan until the electrical supply has been completely disconnected. Lubrication is a primary maintenance responsibility. Check all bearings periodically. Inspect belts for tightness. If the fan is installed in a corrosive or dirty atmosphere, periodically clean the centrifugal wheel, inlet, motor housing and other moving parts.

FAN SHAFT LUBRICATION

Fan shaft bearing pillow blocks are furnished in either the pre-lubricated sealed-for-life type or the greasable type depending on what was ordered. The pre-lubricated type requires no servicing for 7 to 10 years of normal use, and the greasable type are factory greased, eliminating the need for greasing initially. Follow the lubricating schedule recommended by the factory. This practice should not supersede any safety considerations.



When unit positioning necessitates motor mounting to the side of the unit, Pennbarry recommends motors up to 2 HP. Selection of a higher HP motor may void warranty.

LUBRICATION SCHEDULE

Always follow the bearing manufacturer's recommended lubrication schedule. If none is available, use the following general schedule:

- a. Under average conditions where ambient temperatures do not exceed 120°F, lubrication is required 1 to 2 times a year.
- b. In dirt laden atmospheres where there is a temperature range of 120° F to 150°F, lubrication is required from 3 to 6 times a year.
- c. Under extreme temperature conditions and extremely dirty atmospheres, lubrication should be scheduled at least once or twice a month.
- d. Belt driven units maximum temperature should not exceed 160°.
- F. Direct driven models have temperature range stamped on motor.

Table 1: Recommended Lubricants

| Manufacturer | Product | Temp. Range |
|--------------|--------------------|-----------------------------|
| BP | LG-#P-1 | Below 32°F (0°C) |
| Gulf | Gulfcrown EP-1 | |
| Imperial Oil | Unirex EP-1 | |
| Shell | Alvania R-1 | |
| BP | Energrease, MPMK11 | |
| Gulf | Gulfcrown EP-2 | 32°F to 150°F (0°C to 66°C) |
| Imperial Oil | Unirex EP-2 | |
| Shell | Alvania R-3 | |
| Sun Oil | Sun Prestige 42 | |
| Texaco | Regal AFB2 | |

MAINTENANCE

MOTOR LUBRICATION

In general, standard motors are furnished with prelubricated, sealed-for-life ball bearings which require no lubrication for 7 to 10 years of normal service. Where motors have been ordered with greasable bearings, these bearings are factory lubricated and require no attention for one year under normal conditions. If grease relief fittings are provided, remove them when performing maintenance to allow grease to flow out. Whenever possible, apply grease while the motor is running. This practice should not supersede any safety considerations. **DO NOT OVERGREASE**, as most lubricants deteriorate motor windings, thereby reducing motor life and presenting a fire hazard.

HIDDEN DANGER

In addition to the normal dangers of rotating machinery, fans present an additional hazard in their ability to suck in not only air, but loose material as well. Solid objects can pass through the fan and be discharged by the impeller as potentially dangerous projectiles. Therefore, screen intake to ductwork, whenever possible, to prevent the accidental entrance of solid objects. Never open access doors to a duct system with the fan running.

When starting the fan for the first time, completely inspect the ductwork and interior of the fan (with the power locked off), to make certain there is no foreign material which can be sucked into or blown through the ductwork.

Where the fan is accessible to untrained personnel or the general public, use maximum safety guards, even at the cost of some performance loss.



Unprotected fans located less than 7' above the floor also require guarding as specified in the Occupational Safety and Health Act (OSHA).

Centrifugal fans may be connected directly to ductwork which will prevent contact with the internal moving parts, but when the inlet or outlet is exposed, install a suitable guard. PennBarry recommends the use of guards on all exposed non-ducted fans, ceiling and wall mounted.

SPECIAL PURPOSE SYSTEMS

Environments that are explosive, corrosive, subject to high temperatures, etc. may require special construction, inspection and maintenance. It is necessary to observe the fan manufacturer's recommendations and limitations concerning the type of material to be handled by the fan and its application to special conditions.

PARTS REPLACEMENTS

If replacing parts, do so with properly selected components which duplicate the original parts correctly. Incorrectly sized shafts, belts, pulleys, centrifugal wheels, etc. can damage the fan.

Figure 3.a: Direct Drive

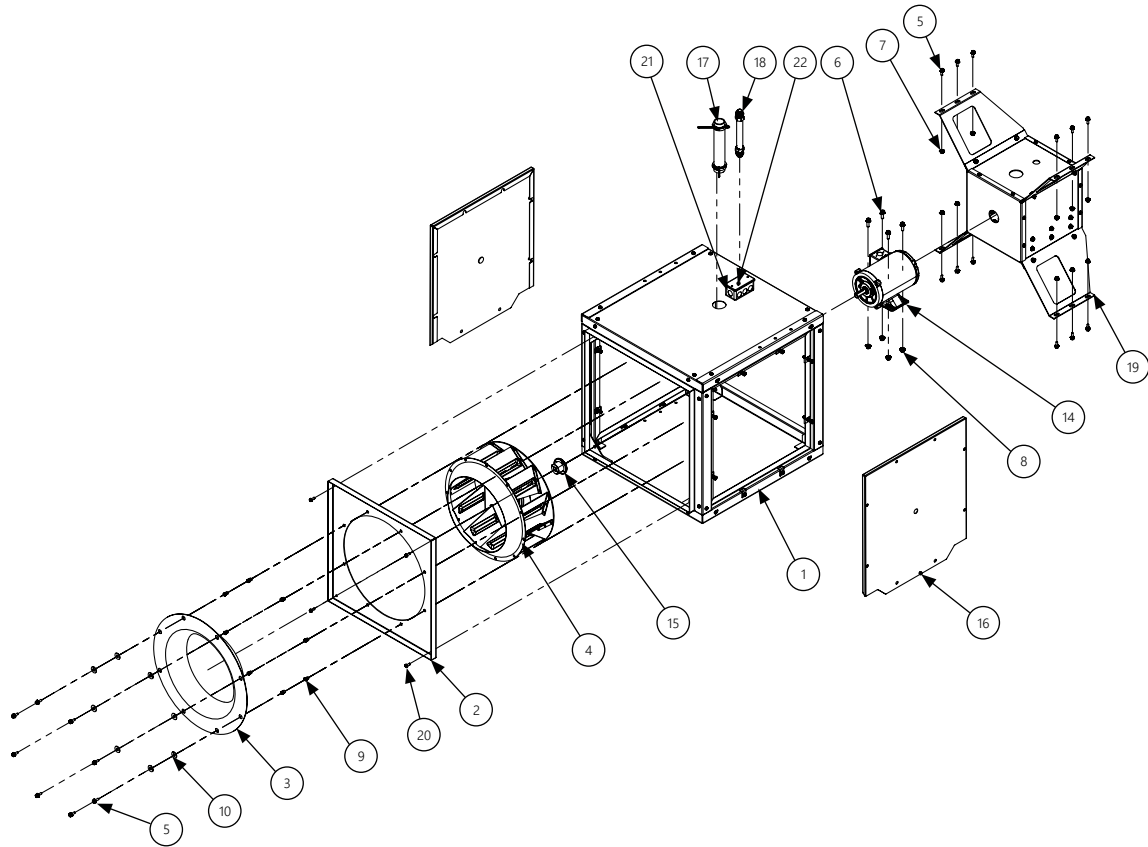

DIRECT DRIVE

- | | |
|--------------------------------|---------------------------------|
| 1. Base Structure Sub Assembly | 12. HHCS 5/16-18 0.75ZP |
| 2. Front Panel | 13. HHCS 5/16-18 1.75ZP |
| 3. Venturi, 165 | 14. As Per Order |
| 4. Wheel Assembly, PRU/PRD 165 | 15. H Bushing 0.625 DIA |
| 5. HHCS WHIZ 1/4-20 0.75 G5 | 16. Access Panel |
| 6. HHCS WHIZ 5/16-18 1.00 Z5 | 17. Cooling Tube, 165 |
| 7. NUT WHIZ 1/4-20 LGFL 12 | 18. Conduit Subassembly, 165 |
| 8. 5/16-18 WHIZ NUT LGFL 44 | 19. Adjustable Motor STR |
| 9. Rivsert 1/4-20 | 20. 1/4-20 X 3/4 Slotted HEX WH |
| 10. Washer 3/8"IDX1"OD | 21. Junction Box |
| 11. Spring NUT 5/16-18 ZP | 22. J-Box Cover |

PARTS REPLACEMENTS

Figure 4: Belt Drive

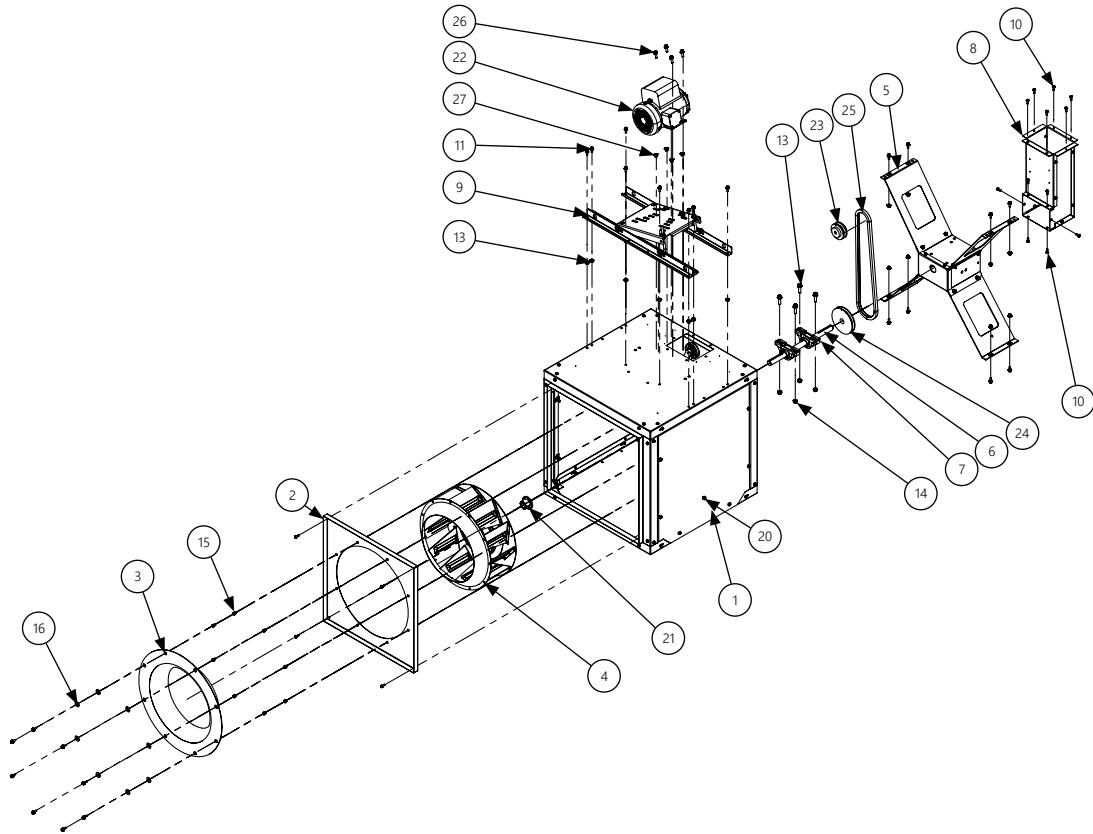

BELT DRIVE

- | | |
|--|-------------------------------|
| 1. Base Structure Sub Assembly | 15. Rivsert 1/4-20 |
| 2. Front Panel | 16. Washer 3/8"IDx1"OD |
| 3. Venturi, 182 | 17. Pring NUT 5/16-18 ZP |
| 4. Wheel Assembly (See Table on Sheet 1) | 18. HHCS 5/16-18 0.75ZP |
| 5. Bearing Cover Assembly | 19. HHcs 5/16-18 1.75zp |
| 6. Shaft (See Table On Sheet 1) | 20. Access Panel |
| 7. Bearing | 21. Bushing H-1.00 |
| 8. Belt Cover Assembly | 22. Motor As Per Order |
| 9. Motor Mount Assembly | 23. Motor Pulley |
| 10. 1/4-20 X 3/4 Slotted HEX WH | 24. Pulley |
| 11. HHCS WHIZ 1/4-20 0.75 G5 | 25. Belt |
| 12. NUT WHIZ 1/4-20 LGFL | 26. HHCS WHIZ 5/16-18 1.00 Z5 |
| 13. Bolt WHIZ 3/8-16 X 1-1/2 | 27. 5/16-18 WHIZ NUT LGFL 44 |
| 14. NUT WHIZ 3/8-16 Flange | 28. 16714406 |

TROUBLESHOOTING CHECKLIST

| Symptom | Possible Cause(s) | Corrective Action |
|---|---|---|
| Excessive noise | 1. Defective or loose motor bearings | 1. Replace motor with same frame size, RPM, HP |
| | 2. Ventilator base not securely anchored | 2. Reset properly |
| | 3. Loose or unbalanced wheel/propeller | 3. Tighten screws, remove build-up, balance wheel/propeller |
| | 4. Misaligned pulleys or shaft | 4. correct alignment |
| | 5. Loose or damaged wheel/propeller | 5. Replace wheel/propeller |
| | 6. Wheel running in wrong direction | 6. Reverse direction |
| Fan inoperative | 1. Blown fuse or open circuit breaker | 1. Replace fuses or circuit breaker |
| | 2. Loose or disconnected wiring | 2. Shut off power and check wiring for proper connections |
| | 3. Defective motor | 3. Repair or replace motor |
| | 4. Broken belts | 4. Replace belts |
| Insufficient Airflow | 1. Open access doors or loose sections of ducts | 1. Check for leakage |
| | 2. Clogged filters | 2. Clean filters |
| | 3. Operation in wrong direction | 3. Correct rotation of wheel |
| | 4. Insufficient make-up air direction | 4. Add make-up fan or louver opening |
| Water leaking into ductwork or collection of grease under fan | 1. Fan installed with slope in the wrong direction | 1. Slope should be fitted in the direction of the drainage opening or grease collection box and drain spout |
| | 2. Clogged drain spout | 2. Clean drain spout |
| | 3. Cooling tube or motor dome top removed | 3. Install new cooling tube with gasket and dome top |
| | 4. Grease container full | 4. Empty grease box |
| Motor overheating | 1. Belt slippage | 1. Adjust tension or replace bad belts |
| | 2. Overvoltage or under voltage | 2. Contact power supply company |
| | 3. Operation in wrong direction | 3. Reverse direction of motor |
| | 4. Fan speed too high | 4. Slow down fan by opening variable pitch pulley on motor shaft |
| | 5. Incorrect motor (service factor 1.0, low ambient temperature) | 5. Replace motor with correct open, NEMA service factors (1.15 or higher) with 40 degrees ambient |
| | 6. Blocked cooling tube or leaky gasket | 6. Remove blockage and seal cooling tube in place |
| | 7. Insufficient airflow to kitchen hood fan operating on low speed with kitchen in full operation | 7. Check airflow under hood and adjust kitchen equipment output |
| | 8. Undersized motor | 8. Check motor ratings with catalog speed and air capacity chart |

Note: Care should be taken to follow all local electrical, safety and building codes. Provisions of the National Electric Code (NEC), as well as the Occupational Safety and Health Act (OSHA) should be followed.

All motors are checked prior to shipment. If motor defects should develop, prompt service can be obtained from the nearest authorized service station of the motor manufacturer while under warranty. Exchange, repair or replacement will be provided on a no charge basis if the motor is defective within the warranty period. The PennBarry representative in your area will provide a name and address of an authorized service station if requested. **WARNING:** Motor guarantee is void unless overload protection is provided in motor wiring circuit.

WHEEL ALIGNMENT PROCEDURES

The wheel position is preset at factory and must rotate freely. However, movement may occur due to rough handling prior to installation and realignment may be necessary. If field correction is required follow these procedures:

1. If "Front to Back" adjustment is required, loosen both motor frame support angles (four nuts), relocate frame, and retighten.
2. If "Side to Side" adjustment is required, loosen both bearings (four nuts), relocate, and retighten.
3. If "Vertical" adjustment is required, loosen both set screws on the wheel hub (accessible from the bottom side of the unit), raise the wheel, and retighten.

Figure 5 Section Thru S/M Screw

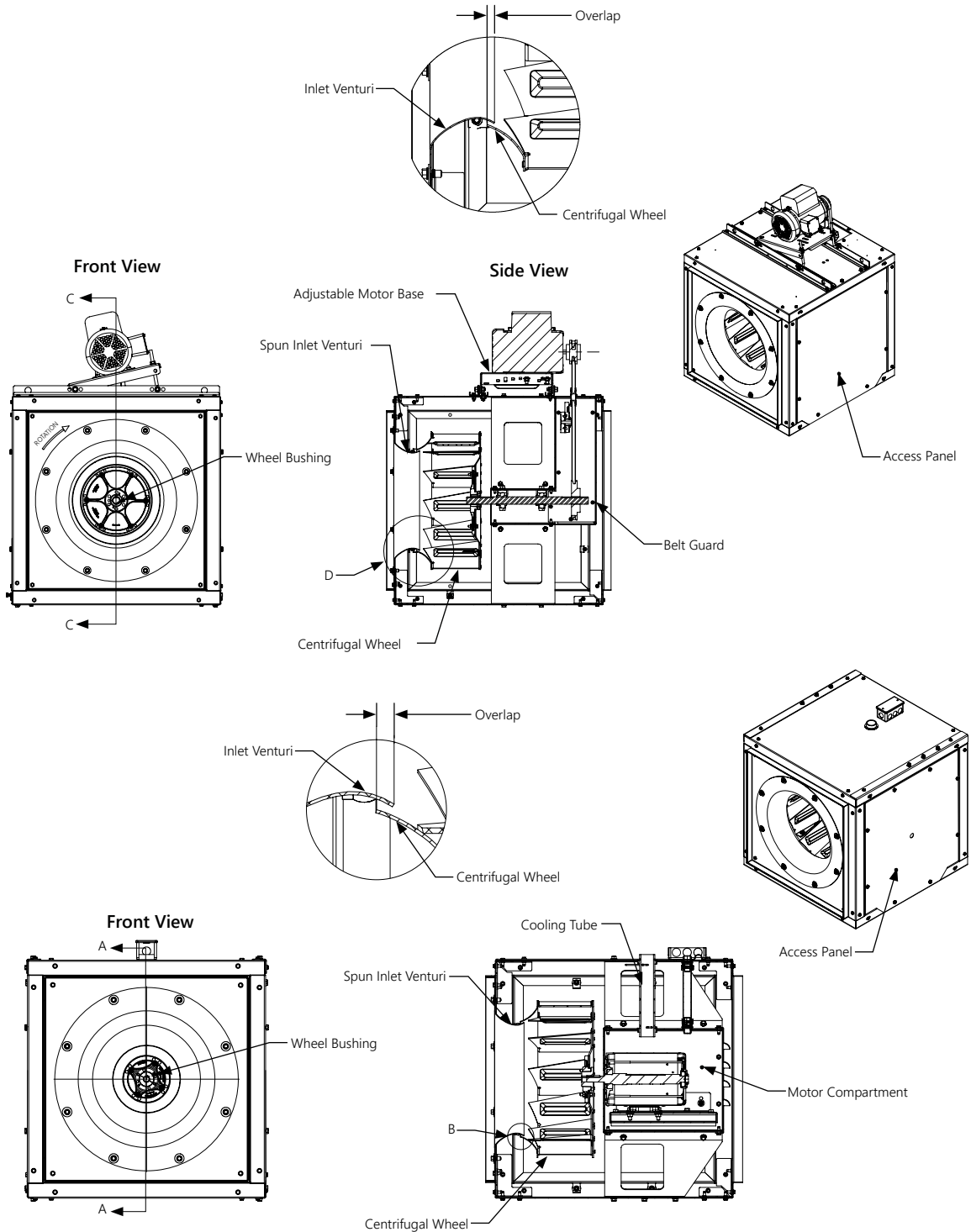

WIRING SCHEMATICS - ECM

1) ODP motors 120v/208v-230v/277v single phase

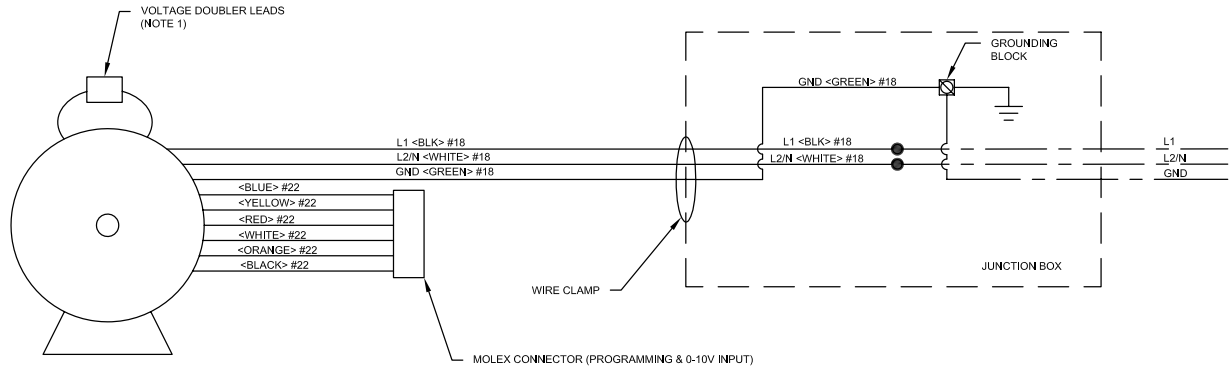

NOTES:

- VOLTAGE DOUBLER LEADS TO BE CONNECTED ONLY FOR 120V. MUST BE DISCONNECTED WHEN 208-277V IS USED.

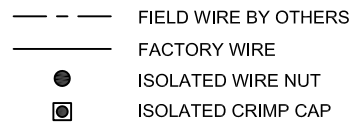

2) ODP motors 120v/208v-230v/277v single phase with external signal harness

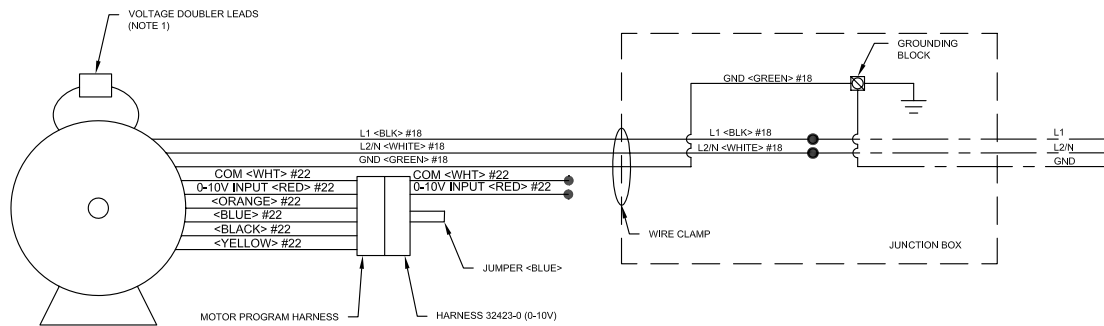

NOTES:

- VOLTAGE DOUBLER LEADS TO BE CONNECTED ONLY FOR 120V. MUST BE DISCONNECTED WHEN 208-277V IS USED.

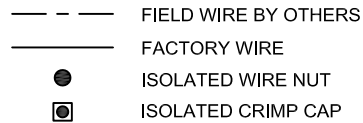

This drawing illustrates our understanding of order requirements. When approved, it represents details for fabrication, as such, PennBarry will not be responsible for revisions in the field or other changes after release for fabrication. Published and protected by PennBarry, Plano, TX. All rights reserved. May not be reproduced partially or in full without permission from the publisher. No rights conveyed to manufacture partially or in full, use or sell either the method of construction represented or any invention in any way related thereto.

WIRING SCHEMATICS - ECM

3) ODP motors 120v/208v-230v/277v single phase (with installed iQ-MS controller)

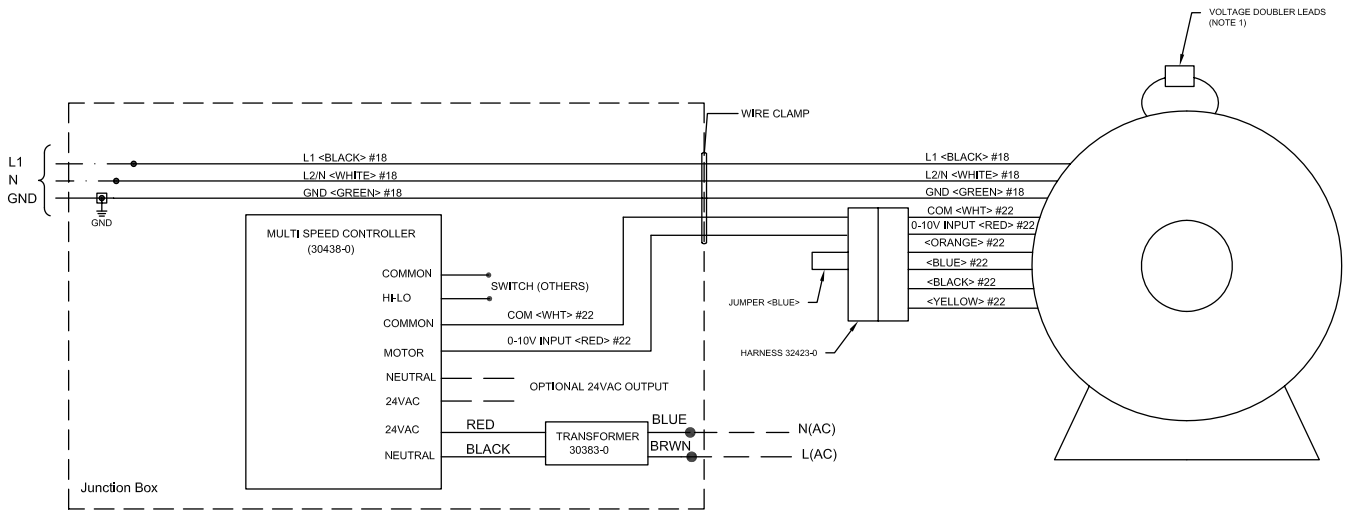

NOTES:

- VOLTAGE DOUBLER LEADS TO BE CONNECTED ONLY FOR 120V. MUST BE DISCONNECTED WHEN 208-277V IS USED.

- FIELD WIRE BY OTHERS
- FACTORY WIRE
- ISOLATED WIRE NUT
- ◻ ISOLATED CRIMP CAP

This drawing illustrates our understanding of order requirements. When approved, it represents details for fabrication, as such, PennBarry will not be responsible for revisions in the field or other changes after release for fabrication. Published and protected by PennBarry, Plano, TX. All rights reserved. May not be reproduced partially or in full without permission from the publisher. No rights conveyed to manufacture partially or in full, use or sell either the method of construction represented or any invention in any way related thereto.

WIRING – PM/AC MOTOR WITH SPEED CONTROLLER/VFD

4) Speed Controller with Three Phase Motor - No Service Switch

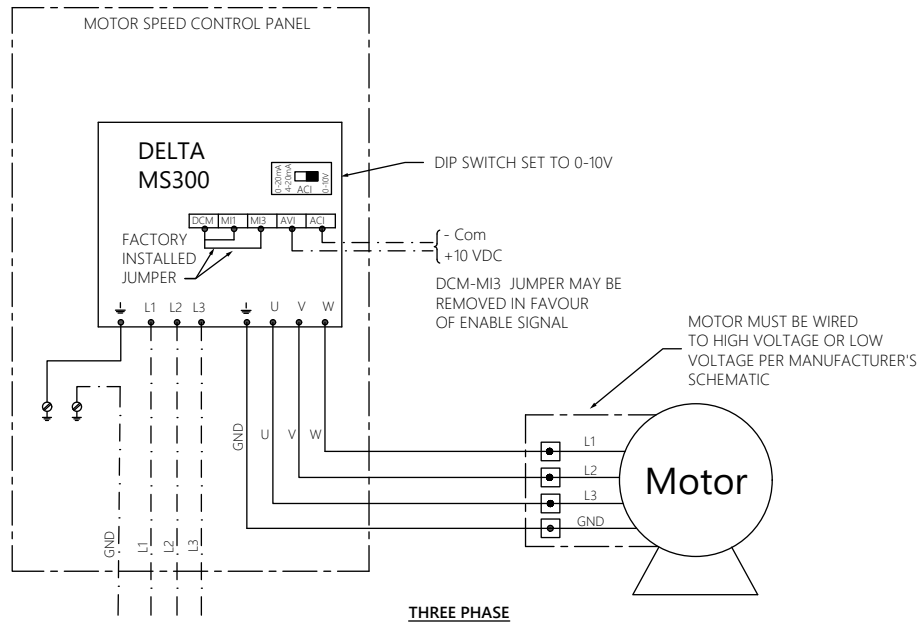

5) Speed Controller with Single Phase Input / 3 Phase Motor - No Service Switch

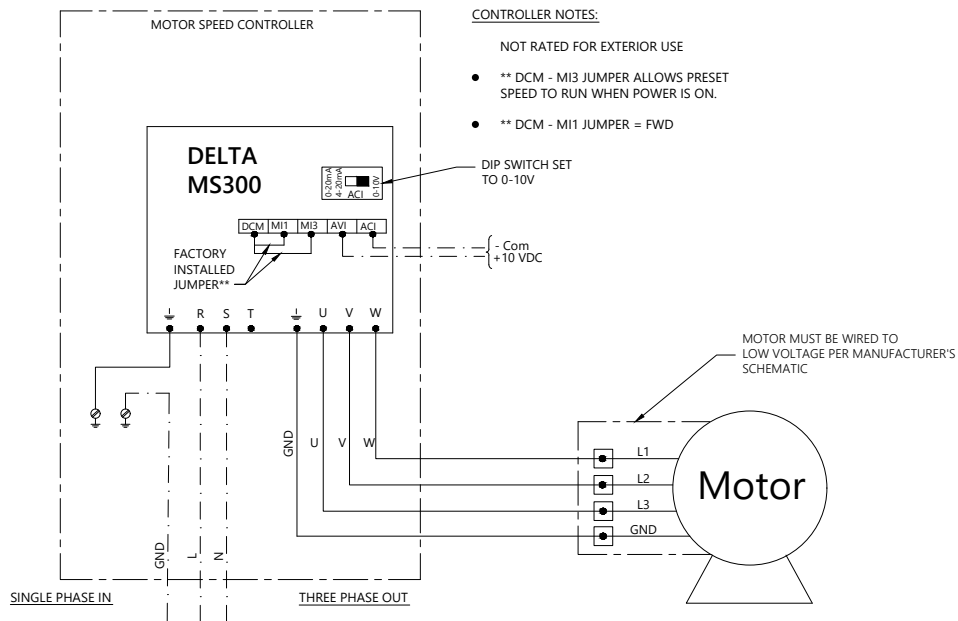

This drawing illustrates our understanding of order requirements. When approved, it represents details for fabrication, as such, PennBarry will not be responsible for revisions in the field or other changes after release for fabrication. Published and protected by PennBarry, Plano, TX. All rights reserved. May not be reproduced partially or in full without permission from the publisher. No rights conveyed to manufacture partially or in full, use or sell either the method of construction represented or any invention in any way related thereto.

WIRING – PM/AC MOTOR WITH SPEED CONTROLLER/VFD

6) Speed Controller with Three Phase Motor - With Service Switch

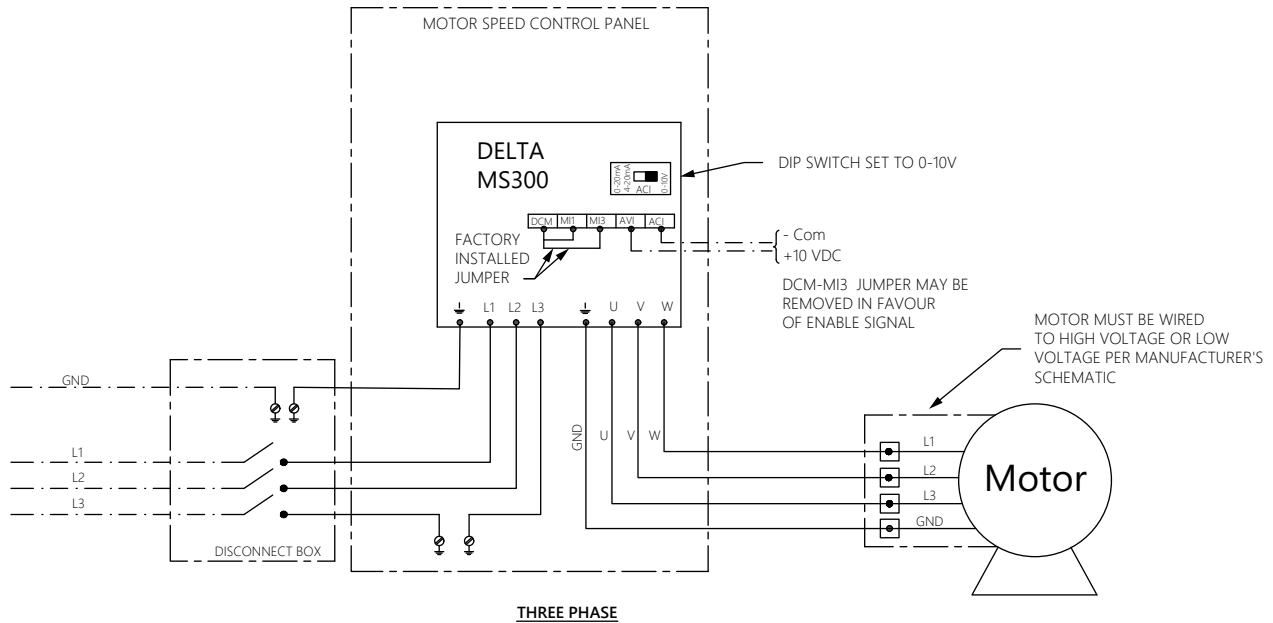

7) Speed Controller with Single Phase Input / 3 Phase Motor - With Service Switch

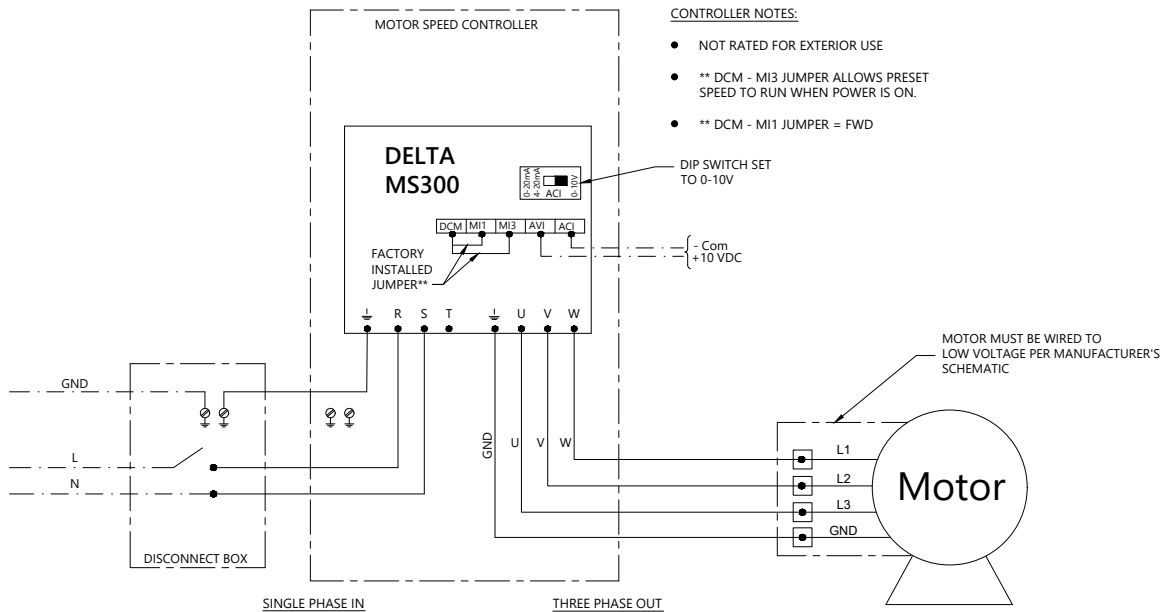

- CONTROLLER NOTES:
- NOT RATED FOR EXTERIOR USE
 - ** DCM - MI3 JUMPER ALLOWS PRESET SPEED TO RUN WHEN POWER IS ON.
 - ** DCM - MI1 JUMPER = FWD

This drawing illustrates our understanding of order requirements. When approved, it represents details for fabrication, as such, PennBarry will not be responsible for revisions in the field or other changes after release for fabrication. Published and protected by PennBarry, Plano, TX. All rights reserved. May not be reproduced partially or in full without permission from the publisher. No rights conveyed to manufacture partially or in full, use or sell either the method of construction represented or any invention in any way related thereto.

WIRING – PM/AC MOTOR WITH SPEED CONTROLLER/VFD

8) VFD with Single Phase Motor - No Service Switch

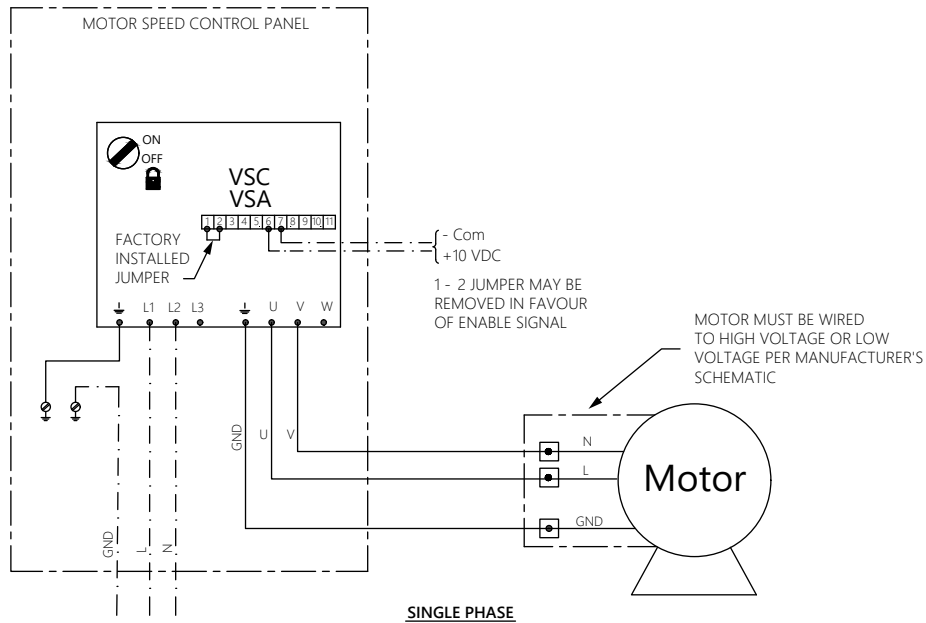

9) Speed Controller with Three Phase Motor - No Service Switch with J-Box installed

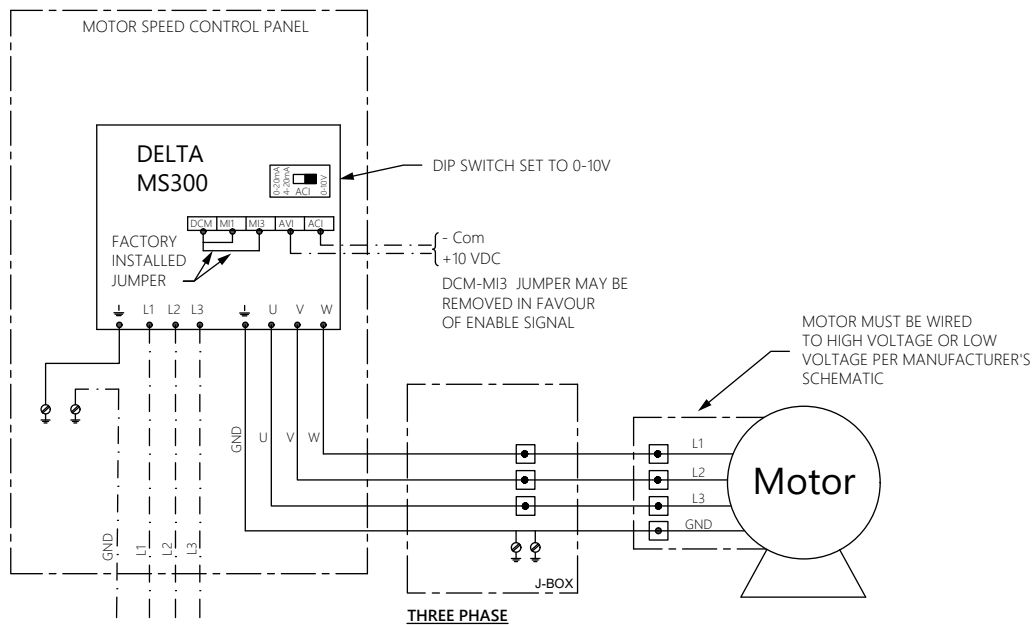

This drawing illustrates our understanding of order requirements. When approved, it represents details for fabrication, as such, PennBarry will not be responsible for revisions in the field or other changes after release for fabrication. Published and protected by PennBarry, Plano, TX. All rights reserved. May not be reproduced partially or in full without permission from the publisher. No rights conveyed to manufacture partially or in full, use or sell either the method of construction represented or any invention in any way related thereto.



PENN BARRY™

PennBarry is proud to be your preferred manufacturer of commercial and industrial fans and blowers. Learn how PennBarry can assist you in your next application by contacting your PennBarry Representative or visiting us on the web at www.pennbarry.com.

PennBarry | www.pennbarry.com | pennbarrysales@pennbarry.com | tel: 972.212.4700 | fax: 972.212.4702

PennBarry reserves the right to make changes at any time, without notice, to models, construction, specifications, options and availability. This manual illustrates the appearance of PennBarry products at the time of publication.

View the latest updates on the PennBarry website.

© 2022 PennBarry. All Rights Reserved. Revised JANUARY 2023